

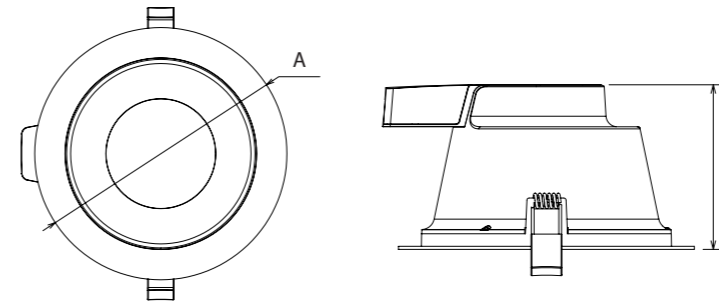

Rocca

DOB Driver on Board LED Downlight



Model	Abmessungen (AxB)mm	Ausschnitt (mm)
UP-DL98B-3-8W	Ø110x70	Ø90-100
UP-DL98B-4-13W	Ø145x82	Ø125-135
UP-DL98B-6-15W	Ø172x95	Ø150-160
UP-DL98B-6-18W		
UP-DL98B-8-15W		
UP-DL98B-8-18W	Ø228x98	Ø200-210
UP-DL98B-8-25W		



Model	Leistung	Spannung	Efficacy	Lumen	CCT	Abstrahlwinkel	UGR
UP-DL98B-3-8W	8W	AC200-240V	100 lm/W	800 lumens	3000K 4000K 5000K 5700K	60° / 90°	19 / 22 / 25
UP-DL98B-4-13W	13W	AC200-240V	100 lm/W	1300 lumens	3000K 4000K 5000K 5700K	60° / 90°	19 / 22 / 25
UP-DL98B-6-15W	15W	AC200-240V	100 lm/W	1500 lumens	3000K 4000K 5000K 5700K	60° / 90°	19 / 22 / 25
UP-DL98B-6-18W	18W	AC200-240V	100 lm/W	1800 lumens	3000K 4000K 5000K 5700K	60° / 90°	19 / 22 / 25
UP-DL98B-8-15W	15W	AC200-240V	100 lm/W	1500 lumens	3000K 4000K 5000K 5700K	60° / 90°	19 / 22 / 25
UP-DL98B-8-18W	18W	AC200-240V	100 lm/W	1800 lumens	3000K 4000K 5000K 5700K	60° / 90°	19 / 22 / 25
UP-DL98B-8-25W	25W	AC200-240V	100 lm/W	2500 lumens	3000K 4000K 5000K 5700K	60° / 90°	19 / 22 / 25

